The background of the entire page is a vibrant blue with a pattern of soft, wavy lines that create a sense of movement and depth. The lines are more pronounced in the lower half and fade slightly towards the top.

# Spirituality in a New Dimension

By Dr. Alan R. Cobb



# Preface

The following discussion about spirituality appeared as a series of articles in Roanoke Baptist Church's newsletter, *The Link*. It was the result of a year-long study with spiritually mature, biblically grounded adults. The purpose of the study and the articles was to develop and present a scientifically based theory about the spiritual realm of our universe which would be an outreach to spiritual seekers, help believers have a better understanding of the spiritual realm, and help scientists accept the Christian worldview as a valid frame of reference for doing scientific studies. We pray that this unique presentation will glorify God and help believers have a sound basis for interacting with spiritual seekers.



# Spirituality in a New Dimension

When we consider the topic of spirituality, we must first ask ourselves what spirituality is.

For some people, spirituality is nothing more than living in a way that they think is in tune or in harmony with the natural forces of the universe. They may not know what those natural forces are or from where those forces originate, but as long as they can live in harmony with them, that is being spiritual.

But for most people, spirituality means a belief that there is another realm beyond the natural world – a realm that is somehow connected to our space – time universe but is not able to be measured directly by any instruments within our universe. This realm may or may not have beings which inhabit it and those beings may interact with our universe. We may even be able to interact with that realm in some way.

The question then becomes, “Is there evidence for the existence of such a realm?” Many scientists deny the existence of such a realm. Scientists are in the business of postulating or theorizing about the way the universe functions and then devising ways to measure those functions to prove their theory is correct. So, because they can’t measure a spiritual realm, they deny its existence.

But is that a valid argument? Those same scientists believe in love and anger even though they can’t directly measure either one. What they can do is

measure the effect of love or anger on a human body and thus proclaim that love and anger exist. In the same way, if we can find evidence of a spiritual realm affecting our space – time universe, then we can proclaim its existence.

Before we can look for evidence, we must first postulate a theory about this spiritual realm. For those who are not inclined to scientific thinking, this may be a bit confusing and difficult to follow, but hang in there and try to understand because if you can it will open up a whole new way of viewing your life.

## The Theory

The three space dimensions of our universe exist at “right” or 90 degree angles to each other.

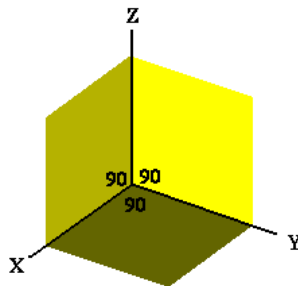

You can see this by looking at a cube. The edges of the cube are the three dimensions: X, Y, and Z. Each side of the cube is a plane formed from two of the dimensions (X-Y, X-Z, and Y-Z). The planes intersect along the dimension line and form a “right” angle to each other.

Time is not a dimension in space but according to mathematicians it exists at “right” angles to the three spatial (space) dimensions. So, a spiritual dimension should

also exist at “right” angles to the three space and one temporal (time) dimensions of our universe.

This is important because if the dimensions are at “right” angles to each other, what happens in only one dimension won’t affect the other dimensions. That means movement along just the X line doesn’t show up in the Y or Z lines. Movement within the X-Y plane will show up along the X and Y dimension lines but won’t show up in either the X-Z or the Y-Z planes or along the Z dimension line. But movement within the interior of the cube will show up on all three planes and all three dimension lines.

Scientists have long suspected that our universe has more than the one temporal and three spatial dimensions that we normally discuss. In fact, there are many scientists who are working with a 10-dimensional universe to try to accomplish the unified field theory that Albert Einstein was trying to develop. So working with a spiritual dimension along with the spatial and temporal dimensions is nothing unique.

What may be unique about the spiritual dimension is whether it is one dimension or three like our spatial dimension. For our theory, we will consider it to be three and refer to them with subscripts as  $X_s$ ,  $Y_s$ , and  $Z_s$ .

Since the spiritual realm has at least one dimension more than the physical realm, it

follows from mathematics that something can exist in the spiritual realm that cannot be detected or observed from the physical realm. Let's use going from two to three dimensions as an example to understand this concept.

A square that exists in only two dimensions would only have length and width (X and Y) but no depth (Z) and would look like figure 1.

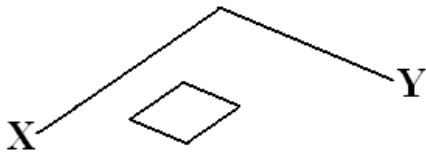

Figure 1

A square that has been given depth by expanding it in a dimension different from either X or Y is called a cube and would look like figure 2. This is the way things look to us living in three dimensions.

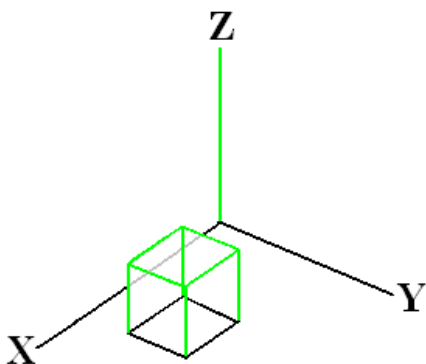

Figure 2

Someone living in just the two dimensions of X and Y (the X - Y realm), would only see the bottom of the cube and it would look the same as figure 1 because they could not see any of the depth which is in the Z dimension. If the cube was raised up off of the plane formed by the X - Y dimension

lines so that none of it intersected with the realm of X - Y (as shown in figure 3), then none of the cube would be visible by someone living only in the X - Y realm.

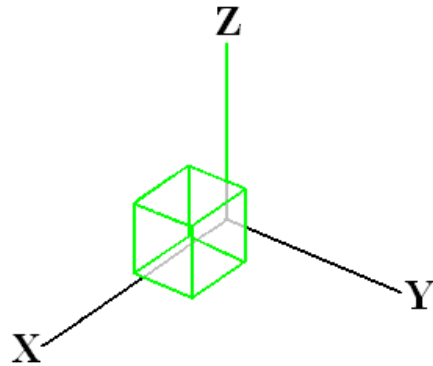

Figure 3

In the same way, the spiritual realm is at least one dimension different from the physical realm just like Z is one dimension different from the X - Y realm. Thus, something in the spiritual realm that does not in some way intersect with the physical realm would not be observed in the physical realm. On the other hand, a single object in the spiritual realm that intersected with the physical realm in different places would appear to be different objects just like the object in figure 4 intersects the X - Y plane to form two separate squares.

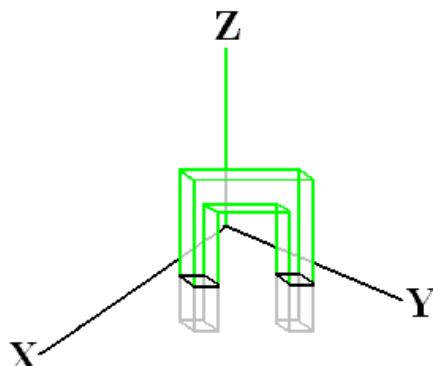
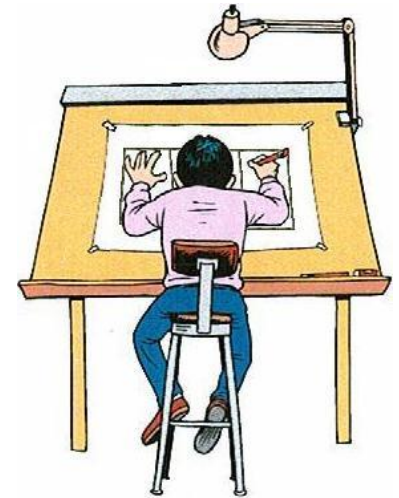

Figure 4

Another result of existing in a realm at least one dimension

greater than another is that you can interact with the lower dimension realm in ways that would appear to be miraculous to residents of that realm. For example, a cartoonist exists in a realm that is one dimension greater than the cartoon he is drawing. (See figure below.)



If he draws a character with dark hair in the first panel of the cartoon, he can change the hair to a light color in the second panel. To the cartoon character, it would seem to be that a miracle occurred, while to the cartoonist it was a simple change. The cartoonist can put his pencil point on a panel and cause an object to appear or put his eraser on an object and make it disappear. To the cartoon character, a miracle has occurred, but to the cartoonist it is simply his interaction with the cartoon realm. The cartoonist can even draw a likeness of himself in the cartoon and thereby interact with his cartoon characters.

So by our theory, a spiritual realm could exist that has at least one dimension and that it exists perpendicular (at a right angle) to our physical realm. And therefore, things in the

spiritual realm might or might not be observed in the physical realm. One object in the spiritual realm could be observed as two or more objects in the physical realm without the physical realm being able to determine that it is one object. And if a being exists in the spiritual realm, he could interact with the physical realm in ways that appeared to be miraculous to someone existing in the physical realm. And he could even have a presence in the physical realm and interact with it while still existing in the spiritual realm.

### **Evidence of a Spiritual Realm**

If our theory about a spiritual realm is correct, we would expect evidence that the spiritual realm has interacted with the physical realm. In the recorded history of the world, from the ancient civilizations to the present, there are stories of miraculous happenings. There are stories of people who have interacted with beings from a spiritual realm. There are stories of people who appeared out of nothingness or disappeared into it. There are stories of people with magical powers who could cause abnormal or miraculous things to happen.

Science, in the age of rationalism, denied that miracles could happen. Scientists investigated supposed miracles, and when the miracle couldn't be duplicated, they declared it was a fake. In some cases they found a previously unknown physical mechanism that provided a rational explanation. But in other cases,

when they couldn't find a rational explanation and couldn't prove it was a fake, they simply proclaimed that what caused the phenomenon was unknown, but that it still wasn't a miracle.

In an article entitled "Quantum Metaphysics" for the book, Modern Spiritualities: An Inquiry, Victor J. Stenger wrote (pp246-247), "To modern dualists, the holistic quantum wave function, with its instantaneous collapse upon the act of observation, has provided a new model for the notion of spirit. They have been wittingly and unwittingly encouraged by various statements made by physicists, some of considerable distinction. ... Physicist Amit Goswami sees a 'self-aware universe,' with quantum mechanics providing support for claims of paranormal phenomena. He says: 'psychic phenomena, such as distant viewing and out-of-body experiences, are examples of the nonlocal operation of consciousness.'"

So from ancient history to modern science we find not only a belief in the existence of a spiritual realm but stories about interactions with it. The Encyclopedia of Spirituality (p18) says, "Shamanism teaches that the world is permeated by spirits who directly impact human life and without whose help we could not survive."

Judaism records in the Torah that three spiritual beings visited the patriarch Abraham and ate with him. That evening, two of the beings caused some men of Sodom to become blind, and then destroyed the cities of Sodom and Gomorrah by

raining fire from the sky the next morning. The Torah also reports that a spiritual being talked with Moses through a bush that was on fire but not burned up. Judaism says that a Jewish king asked a medium to consult the spirit of a dead prophet and received an answer.

Christianity reports that a spiritual being caused a baby to grow in the womb of a virgin and that she gave birth to that baby. It also reports that spirits living in the body of a man were forced to leave those bodies and inhabit the bodies of pigs. Something that resembled tongues of fire were witnessed falling from the sky and coming to a rest over the heads of 120 individuals who then exhibited the ability to be understood in languages that they had never spoken before.

Many people down through history report that they communicated with spiritual beings or saw and felt the effects of the presence of spiritual beings.

With all of this anecdotal evidence, the existence of a spiritual realm is fairly well established. Now we need to describe how humans function within this universe that includes both physical and spiritual realms and the dimension of time.

### **Humans and the Spirit Realm**

Both ancient and modern religions believe that a spiritual realm exists and that there are beings who exist in that realm. They also believe that those spirit beings can and have interacted with the physical realm. Sometimes that

interaction is by assuming a physical form, sometimes it is just a thought in a human's mind, and sometimes a human may detect the interaction through one of their five senses. Those spirit beings are not believed to exist in both the physical and spiritual realms but only in the spiritual.

Plato and other early philosophers believed that humans had a body, a soul, and a spirit. This agrees with ancient religions as well as modern religions such as Islam, Wicca, Judaism, and Christianity. This tripartite (three-in-one) being of humans can best be described as a physical body that exists in the physical realm, a spiritual body that exists in the spiritual realm, and a soul which consists of mind, will, and emotions that control and connects both bodies. Figure 1 depicts how that tripartite being may occur.

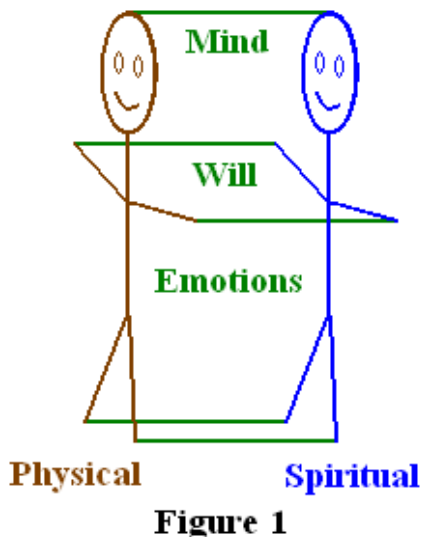

**Figure 1**

So, if humans have both a physical body and a spiritual body, why don't we function and interact regularly with the spiritual realm like we do the physical realm?

According to some religions,

like Wicca, humans can function in the spiritual realm. They believe that by simply repeating the correct words or performing the correct actions in the physical realm a person can cause an action to happen in the spiritual realm. That action may or may not be known by an action in the physical realm.

According to Judaism and Christianity, humans cannot function in the spiritual realm because they disobeyed a command of their Creator and therefore were separated from their spiritual bodies. The separation of the soul (mind, will and emotions) from the spiritual body is described as a death. We can call that a spiritual death and depict it as in Figure 2.

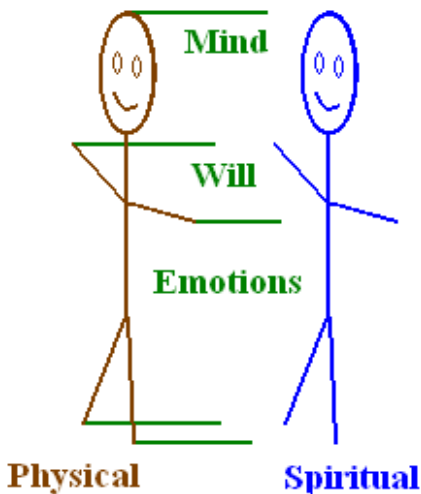

**Figure 2**

According to Wicca, Judaism, and Christianity, humans can interact with the spiritual realm, even if they have died spiritually, by allowing a being from the spiritual realm to reconnect their physical and spiritual bodies by filling the gap. That connection is called channeling by Wiccans and possession by

Judaism and Christianity. Figure 3 depicts reconnection by a spirit being.

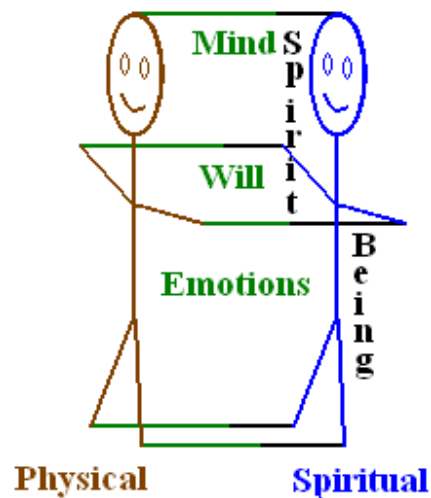

**Figure 3**

What happens when a spirit being is allowed to bridge the gap between our physical and spiritual bodies? That spirit being is now in direct contact with our mind, will, and emotions and thus able to control our spiritual body in the spiritual realm. Direct contact with our mind makes it easy for the spirit being to give us thoughts that we would think were our own. It is similar to allowing a person to hypnotize you. That allows the hypnotist to be in direct contact with your mind and give you suggestions that you accept as your own and as the truth. Thus with a delayed suggestion, he can cause you to act like a chicken and do things totally out of your normal character.

Direct contact with our emotions makes it easy for the spirit being to trigger emotional reactions (hunger, fear, love, joy, etc.) in our physical body. Thus a hypnotist by suggestion can make you feel sick even when you are perfectly healthy. And he can make you think



your arm is a steel rod so that you feel it is impossible to be bent. He can also make you think that something that normally causes pain will not cause pain. Some dentists have used this to be able to work on a patient's teeth without using any anesthesia.

The will seems to be the only one of the three where direct contact doesn't make it easy for the spirit being to affect us. Hypnotists say that a person can't be made to do anything under hypnosis that they don't believe is morally right to do and wouldn't do if not hypnotized. Mediums who regularly contact the spirit realm speak of inviting the spirit being to take control of them before they go into a trance. But other people who have been allowing a spirit being to have control sometimes say that the being takes control when they haven't invited them to and even when they don't want them to have control. So it appears that allowing a spirit being to bridge the gap and have control could be a very dangerous thing to do.

### **Practical Application**

Let's take the theory that we have developed and what we have learned from it and apply that to some specific examples of interaction with the spiritual realm. Going to the writings of most religions would show us claims of interactions with spirit beings. An in depth look at the claims of all religions would be impossible to cover in a reasonable time in a monthly publication like this. So, let's look at the claims of one religion that may have more

claims than any other – Christianity. In looking at Christianity, we are really looking at Judaism as well because they both use the same writings for what Christianity calls the Old Testament. You can follow the same process with other religions that you would like to consider.

The first step in examining the claims of any religion is to outline their overall view of the spiritual realm.

### **In the Beginning ...**

Judaism and Christianity both claim that the universe, in its entirety, was created by a being who exists outside of the universe. Genesis 1:1 says, "In the beginning God created the heavens and the earth." Then Genesis goes on to describe the creation of light and everything else in the universe and shows how man fits into it. John 1:1-3 says, "In the beginning was the Word, and the Word was with God, and the Word was God. He was with God in the beginning. Through him all things were made; without him nothing was made that has been made."

This being who is called God and the Word must exist outside of the universe because he creates it out of nothing. By the scientific study we did earlier, that means the being exists outside of the physical realm, the spiritual realm and the dimension of time just like a cartoonist exists outside of the cartoon that he creates. (From this point on I will refer to the being as God so our discussion will correlate with the Jewish and Christian writings.)

### **God – Spiritual and Physical**

The Jewish writings which Christians call the Old Testament are full of statements that God has or is a spirit. For example, Genesis 1:2 says, "... the Spirit of God was hovering over the waters." That means God has an existence in the spiritual realm. There are other statements that say God can have an existence in the physical realm. For example, Exodus 13:21 says, "By day the Lord (meaning God) went ahead of them in a pillar of cloud ... and by night in a pillar of fire." And Exodus 3 shows God appearing as a burning bush that wasn't consumed by the fire.

The First Century writings of Jews who became known as Christians also claim that God has an existence in the spiritual and physical realms. For example, John 4:24 says, "God is Spirit." And John 1:14 says, "The Word (God) became flesh and lived for a while among us."

So Judaism and Christianity are founded upon the idea that a being, called God, created the universe out of nothing. By our theory, that means he exists outside of the universe just like a cartoonists exists outside of his cartoon. Both claim that the universe exists as physical and spiritual realms permeated by a dimension called time. God, who created time along with the physical and spiritual realms, exists outside of them and appears in them whenever and however he desires, just as a cartoonist can draw himself into his cartoon whenever and however he desires.

## **Physical and Spiritual Interactions**

By our theory, since the spiritual realm is of a dimension greater than the physical realm, a being existing in the spiritual realm should be able to interact with the physical realm. That interaction could be exhibited as the power to cause changes in the physical realm or even the appearance as an object in the physical realm.

Some examples of these types of interactions found in Jewish writings are:

The Lord and two angels appearing as men and eating and talking with Abraham before the two angels go to destroy Sodom and Gomorrah. (Genesis 18 & 19)

The bush which did not burn up through which God spoke to Moses. (Exodus 3)

The Lord leading the Israelites on their exodus out of Egypt as a pillar of smoke by day and a pillar of fire by night. (Exodus 13:20 – 22)

Angelic creatures with the form of a man appearing to Ezekiel but with each also having the face of a lion, an ox, and an eagle and each having two sets of wings. (Ezekiel 1)

The Christian writings also describe interactions between the spiritual and physical realms.

An angel, identified by the name of Gabriel, appears to Mary to announce that she has been chosen to bear God's Son

by the power of the Holy Spirit. (Luke 1)

When Joseph learns from an angel about Mary's child and is told to name him Jesus, the writer explains that it was to fulfill what the Jewish writer, Micah, wrote that he would be called Immanuel which means God with us. That shows that Jesus is the presence of God in the physical realm. (Matthew 1)

An angel appears to shepherds out in a field and announces that Jesus, the Savior, has been born. (Luke 2)

The Holy Spirit, God's presence in the Spiritual realm, appears as a dove at the baptism of Jesus. (Matthew 3)

The Holy Spirit appears as tongues of fire that settle on the disciples on the day of Pentecost and gives them power. (Acts 2)

Most of the book about the revelation of Jesus, which God gave him to show to the Apostle, John, describes events in the spiritual realm that have effects in the physical realm. Angels pour the wrath of God out of bowls and the result in the physical realm is painful sores, water turning to blood, the sun becoming so hot it scorches people, parts of the earth being plunged into total darkness so that it causes men to be in agony, the Euphrates River is dried up, evil spirits looking like frogs come out of the mouths of three people and perform miracles to lead people to follow Satan, a spiritual being. (Revelation 16)

The Jewish and Christian writings show events in the spiritual realm having the power to affect the physical realm. They show God having a presence in the spiritual realm as the Holy Spirit and in the physical realm as Jesus.

## **The Holy Spirit Interacting with the Physical Realm**

The examples at which we previously looked showed that the Holy Spirit (God's presence in the spiritual realm) has appeared in the physical realm. Our theory would predict that as a being in the spiritual realm interacted with the physical realm the interaction could be perceived by beings in the physical realm as miraculous powers.

The following are examples from the Jewish writings of the Holy Spirit interacting with the physical realm.

Moses is said to have had the Holy Spirit resting on him and then God took of that Spirit and put it on seventy of the Israeli elders who then were each able to prophesy for one time. (Numbers 11:25)

“When Balaam looked out and saw Israel encamped tribe by tribe, the Spirit of God came upon him and he uttered his oracle.” (Numbers 24:2)

The Spirit of the Lord came upon Samson giving him the power to tear a lion apart with his bare hands. (Judges 14:6)

The Jewish writings describe the Holy Spirit as resting on an individual and giving that

person special powers such as prophesy or strength. This agrees with our theory.

The following are examples from the Christian writings of the Holy Spirit interacting with the physical realm.

When Jesus was baptized the Holy Spirit appeared in the form of a dove and descended and lighted upon Jesus. The voice of God spoke from heaven and said, "This is my Son, whom I love; with him I am well pleased." (Matthew 3:16-17; Mark 1:9-11; Luke 3:21-22)

After his baptism, the Holy Spirit directed Jesus to go into the desert where he ate nothing for forty days and was tempted by the Devil, a being from the spiritual realm. (Matthew 4:1-11; Luke 4:1-13)

After he was crucified and resurrected, Jesus suddenly appeared before his disciples in a locked room. He breathed on them and said, "Receive the Holy Spirit." (John 20:19-22)

Fifty days after Jesus was crucified, the Holy Spirit descended from heaven with the sound of a violent wind and in a form like tongues of fire came to rest on the believers who then began to speak in other tongues as the Spirit enabled them. (Acts 2:1-4)

Philip, one of the early disciples of Jesus, told an Ethiopian about Jesus and baptized him. Suddenly, Philip was taken away by the Spirit of the Lord so that the Ethiopian could not see him. (Acts 8:34-40)

These examples show the

Holy Spirit indwelling humans and giving them miraculous powers. This agrees with our theory.

### **God and the Physical Realm**

The following examples from the Jewish writings show God having a presence in the physical realm.

Genesis 16 describes the angel of the Lord meeting a woman named Hagar, telling her that she is pregnant and what the temperament of her child would be, and saying that he would make the number of her descendants too numerous to count.

In Genesis 22:15 – 17, the angel of the Lord says to Abraham, "I swear by myself, declares the Lord, that because you have done this and have not withheld your son, your only son, I will surely bless you and make your descendants as numerous as the stars in the sky and as the sand on the seashore."

Numbers 22 describes the angel of the Lord confronting a man named Balaam riding a donkey. The donkey is able to see the angel of the Lord while Balaam can't. The angel of the Lord gives the donkey the power to speak to Balaam. The angel of the Lord then opens the eyes of Balaam so that he can also see him.

These examples show that the Angel of the Lord is God appearing in the physical realm and interacting with it in ways that appear supernatural or

miraculous. This is exactly what our theory predicts.

The following examples of God having a presence in the physical realm come from the Christian writings.

Matthew 1 and Luke 1 describe a being from the spiritual realm (called an angel and named Gabriel) saying that Mary would have a baby who is the Son of God and that he would be named Jesus.

Matthew 8:1 – 4; Mark 1:40 – 45; and Luke 5:12 - 16 describe Jesus touching a man and healing him of the disease of leprosy.

Matthew 8:23 – 27; Mark 4:35 – 41; and Luke 8:22 – 25 describe Jesus speaking to the wind causing a furious squall and waves about to capsize a boat in which he was sleeping. When he speaks to the wind, it dies down and the waves become calm.

John 2:1 – 11 describes Jesus turning water into wine.

Matthew 14:22 – 36; Mark 6:45 – 56; and John 6:16 – 24 describe Jesus walking on the surface of the water and enabling Peter to do the same.

John 11:38 – 44 describes Jesus healing a man named Lazarus who had been dead for four days.

These examples show God having a unique presence in the physical realm, having been born as a baby and given the name Jesus, grown into

manhood and having power to control the physical realm. This is exactly what our theory predicts for a being who exists outside of our universe.

### **God in the Spiritual Realm**

The following are from the Jewish writings.

“In the beginning God created the heavens and the earth. Now the earth was formless and empty, darkness was over the surface of the deep, and the Spirit of God was hovering over the waters.” Gen 1:1-2

“Then the Lord said to Moses, ‘See, I have chosen Bezalel ... and I have filled him with the Spirit of God, with skill, ability and knowledge in all kinds of crafts ...’” Ex 31:1-5

“The Spirit of God has made me; the breath of the Almighty gives me life.” Job 33:4

“The Lord said to Moses, ‘I am going to come to you in a cloud, so that the people will hear me speaking with you’ ... Mount Sinai was covered with smoke, because the Lord descended on it in fire. ... Then Moses spoke and the voice of God answered him.” Ex 19:9, 18-19

The Jewish writings indicate that God has a presence in the spiritual realm called the Spirit of God. The Spirit of God interacts with the physical realm to give life to people, to talk with people, and to empower them to accomplish things for which they have no training.

The following are from the Christian writings.

“As soon as Jesus was baptized, he went up out of the water. At that moment heaven was opened, and he saw the Spirit of God descending like a dove and lighting on him. And a voice from heaven said, ‘This is my Son, whom I love; with him I am well pleased.’” Matt 3:16-17

“God is spirit, and his worshipers must worship in spirit and in truth.” John 4:24

“The Spirit gives life; the flesh counts for nothing. The words I have spoken to you are spirit and they are life. Yet there are some of you who do not believe.” John 6:63-64

“Jesus answered, ‘I tell you the truth, unless a man is born of water and the Spirit, he cannot enter the kingdom of God. Flesh gives birth to flesh, but the Spirit gives birth to spirit.’” John 3:5-6

“But the Counselor, the Holy Spirit, whom the Father will send in my name, will teach you all things and will remind you of everything I have said to you.” John 14:26

“All of them were filled with the Holy Spirit and began to speak in other tongues as the Spirit enabled them.” Acts 2:4

“And if the Spirit of him who raised Jesus from the dead is living in you, he who raised Christ from the dead will also give life to your mortal bodies through his Spirit, who lives in

you.” Rom 8:11

The Christian writings indicate God has a presence in the spiritual realm, called the Spirit or Holy Spirit. The Spirit is sent to live in those who believe in Jesus, gives life to the spirit of those people and empowers them to accomplish miraculous things.

Our theory agrees with what the Jewish and Christians indicate about God in the spiritual realm interacting with the physical realm and empowering physical beings to do things that seem miraculous.

### **God as a Human**

The Christian writings say God became a human while at the same time being the Son of God (Matt 1:18; Luke 1:35; John 1:1-4, 14); that he lived among us to reveal God to us (John 14:9); that he had power over the physical realm (Matt 8:26; 9:2-7) and over spirit beings (Matt 8:28-32); that he died to pay for man’s disobedience (Rom 5:8; 1 Cor 15:3-4; 1 Pet 3:18) so that he could restore man to the eternal life he would have had with God, the Creator, if the first man had not disobeyed (John 3:16; Rom 5:12, 17; 6:23; 8:1-11); that he died and after three days rose alive from the dead in a body that was not limited by the physical universe but could still participate in it (Matt 28:5-7; Luke 24:36-43; John 20:19-28); that he would send the Spirit of God to dwell in those who believed and trusted him (John 14:15-21); and that he would return to take his followers to live with him (John 14:1-3).

The Jewish writings also show that God would send a Messiah (Savior), born of a virgin and called Immanuel (God with us) (Isaiah 7:14); that he would also be called Wonderful Counselor, Mighty God, Everlasting Father, Prince of Peace and reign on (King) David's throne to establish justice forever (Isaiah 9:6-7); that he would be gentle yet establish justice and would heal people (Isaiah 42:1-9; 61:1); that he (the Savior) is God (Isaiah 43:10-13; 45:18-23); that he would not only save the Jews but also the Gentiles (Isaiah 49:5-8); that he would be rejected, despised, and killed for the sins of people (Isaiah 52:13 – 53:12).

Our theory says that a being existing outside of our physical – spiritual – temporal universe could manifest himself within that universe like a cartoonist drawing himself into the cartoon he creates. Although that being would have power over the universe that seems miraculous, he could also subject himself to the laws operating in the universe by any amount that he desired and for any time period that he desired. He could even be birthed as a human baby and grow and live like any normal human. But he could also exert miraculous powers over both the physical and spiritual realms at any time and in any way that he desired. Since he exists outside of the universe, he could exist in both the physical and spiritual realms at the same time, and it would be possible for him to say to a person in the physical realm, “receive my spirit” while in the spiritual realm bridging the gap between the person's physical

and spiritual bodies. That person could then have miraculous powers in the physical realm because of the being's existence in the spiritual realm.

Our theory, which is based on science and math, predicts exactly what is historically described by both the Jewish and Christian writings. Thus our theory is experientially proven as a reliable basis for describing and predicting the way events happen in our universe. It also shows that Judaism and Christianity are scientifically based views of reality and worthy of being studied by scientists and the entire scientific community.

I hope you have enjoyed this study and will share it with as many people as you can.

If you would like to discuss any of the ideas in this booklet with me, you may write to me at Roanoke Baptist Church, 3950 Wyoming, Kansas City, MO 64111, or [alancobb@juno.com](mailto:alancobb@juno.com).